

LV463 IO-Link

Amplifier for fiber optics

en 02-2014/04 50125193



up to 1050mm  
 up to 270mm  
 10 - 30 V DC  
 Ø 2.2mm  
 IO-Link

- Two, large, easy-to-read displays for the simultaneous display of the signal value and the switching threshold
- IO-Link with additional switching output (Dual Channel)
- Three different teach modes for fast sensor adjustment
- Switch for changing between light and dark switching

Dimensioned drawing

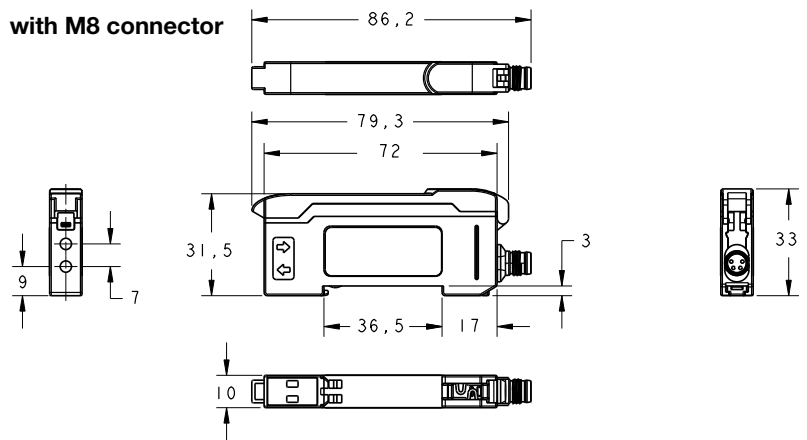
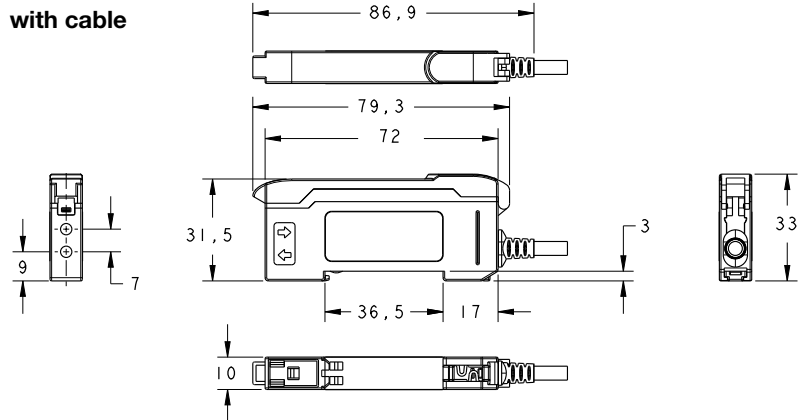

Mounting accessories

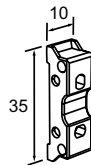

BTU LV463  
Part no. 50120869

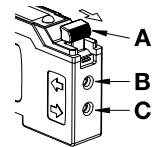

- A** Clamping lever for fiber optic cable (unlock in direction of arrow)
- B** Connection for fiber optics receiver
- C** Connection for fiber optics transmitter

Electrical connection

4-pin plug

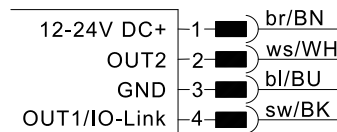

4-wire cable

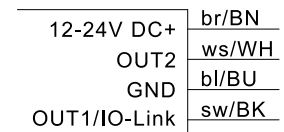

**NOTE:** Open lead wires must be connected to a terminal box.

We reserve the right to make changes • DS\_LV463\_7L4\_en\_50125193.fm

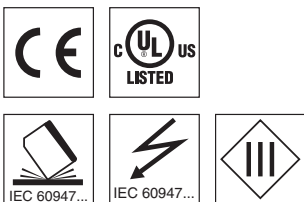

Accessories:

(available separately)

- Plastic fiber optics (KF, KFX)
- Ready-made cables (KB ...)
- Mounting device (BTU LV463)

## Specifications

<b>Optical data</b>		<b>Throughbeam principle</b>	<b>Scanning principle</b>		
Operating range/scanning range <sup>1)</sup>		up to 1050mm	up to 270mm		
Light source		LED (modulated light)			
Wavelength		660nm (visible red light)			
<b>Timing</b>		≤ 500ms			
Delay before start-up					
	<b>Signal range</b>	<b>High Speed (HS)</b>	<b>Standard (STD)</b>	<b>Long Range (LR)</b>	<b>Extra Long Range (XLR)</b>
Response time		200µs	500µs	2000µs	5000µs
Switching frequency <sup>2)</sup>		2500Hz	1000Hz	250Hz	100Hz
Display area (digits)		0 ... 4000	0 ... 4000	0 ... 9999	0 ... 9999
<b>Sensor operating modes</b>		COM2			
IO-Link		standard push-pull			
SIO		yes			
Dual Channel					
<b>Electrical data</b>		SIO mode: 12 ... 24VDC ± 10 %			
Operating voltage U <sub>B</sub> <sup>3)</sup>		COM2 mode: 18 ... 24VDC ± 10 %			
Residual ripple		≤ 10% of U <sub>B</sub>			
Open-circuit current		≤ 40mA @ 24VDC			
Switching output	.../L4...	pin 4/bk: IO-Link SIO mode, Push-pull (PNP light switching, NPN dark switching)			
		pin 4/bk: IO-Link COM2 mode			
Function		pin 2/wh: PNP dark switching			
Switching output time functions		light/dark switching, adjustable by means of a switch switch-on/-off delay, passing contact (on actuation or fall-back), (combinations are limited → <i>Combinations of timing functions</i> )			
Adjustable times (time functions)		0 ... 9999ms			
Signal voltage high/low		≥ (U <sub>B</sub> -2.5V)/≤ 2.5V			
Output current		≤ 100mA			
Sensitivity		adjustable using the teach function or +/- buttons			
<b>Indicators</b>		switching output active			
Yellow LED		2 x 7-segment LED, 4-digit,			
Display		red: signal strength, green: switching threshold			
<b>Mechanical data</b>		ABS/PC black/red, transparent PC cover			
Housing		50g with M8 connector			
Weight		63g with 2000mm cable			
		70g with 150mm cable and M8/M12 connector			
Connection type		M8 connector, 4-pin, or 2000mm cable, 4 x 0.25mm <sup>2</sup> , or 150mm cable with M8 connector, 4-pin, or 150mm cable with M12 connector, 4-pin			
Fibre optic cable connection		clamp-mounting, 2 x Ø 2.2mm			
<b>Environmental data</b>		-10°C ... +55°C/-20°C ... +85°C			
Ambient temp. (operation/storage)		2, 3			
Protective circuit <sup>4)</sup>		IP 50, NEMA 1			
Protection class		EN 60947-5-2			
Standards applied		UL 508, C22.2 No.14-13 <sup>3) 5)</sup>			
Certifications					
<b>Options</b>		menu-driven by means of display/rocker push button or via IO-Link			
Sensor adjustment					

## Remarks



### Notice!

Detailed specifications on the range/scanning range are enclosed in the data sheets of our fiber optics type **KF** or **KFX**.

### Explanation of the signal areas

#### High Speed (HS):

shortest response time; shortest operating range

#### Standard (STD):

response time and operating range suitable for many standard applications

#### Long Range (LR):

long operating range; high-resolution display format; response time somewhat shorter

#### Extra Long Range (XLR):

longest operating range; high-resolution display format; short response time

- 1) Range/scanning range depending on the fiber optics used
- 2) With a duty cycle of 1:1
- 3) For UL applications: for use in class 2 circuits according to NEC only
- 4) 2=polarity reversal protection, 3=short circuit protection for all outputs
- 5) These proximity switches shall be used with UL Listed Cable assemblies rated 30V, 0.24A min, in the field installation, or equivalent (categories: CYJV/CYJV7 or PVVA/PVVA7)

Additional information on the IO-Link can be found on the Internet at [www.leuze.com](http://www.leuze.com).

## Order guide

	Designation	Part no.
<b>IO-Link models</b>		
Connection: M8 connector, 4-pin	LV463.7/L4-M8	50122456
Connection: cable 2000 mm, 4 x 0.25mm <sup>2</sup>	LV463.7/L4	50122460
Connection: cable 150mm with M8 connector, 4-pin	LV463.7/L4-150-M8	50122459
Connection: cable 150mm with M12 connector, 4-pin	LV463.7/L4-150-M12	50122457

### ● Approved purpose:

This product may only be used by qualified personnel and must only be used for the approved purpose. This sensor is not a safety sensor and is not to be used for the protection of persons.

**IO-Link process data**

The sensor transmits 2 bytes to the master.

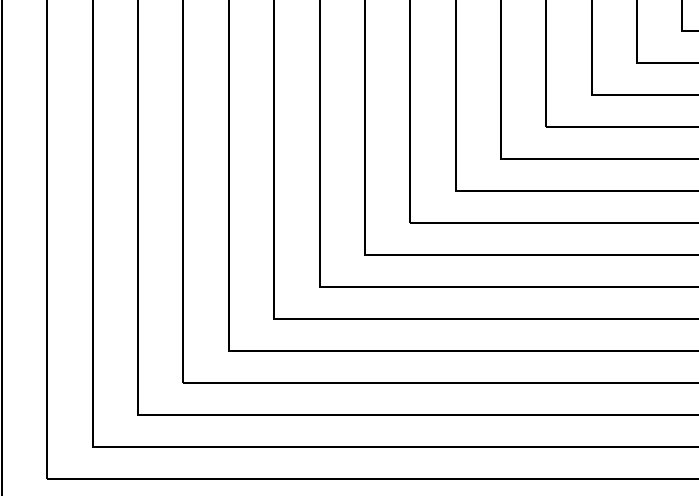
Data bit																Assignment	Default settings
15	14	13	12	11	10	9	8	7	6	5	4	3	2	1	0		
																Switching output	Object detection
																Error message	e. g. Teach error
																Measurement value LSB	Value range 0 ... 9999 0 = min. signal level 9999 = max. signal level
																Measurement value	
																Measurement value	
																Measurement value	
																Measurement value	
																Measurement value	
																Measurement value	
																Measurement value	
																Measurement value	
																Measurement value	
																Measurement value	
																Measurement value	
																Measurement value	
																Measurement value	
Measurement value MSB																	



Additional information on the IO-Link service data can be found on the Internet at [www.leuze.com](http://www.leuze.com).

### Mounting the amplifier

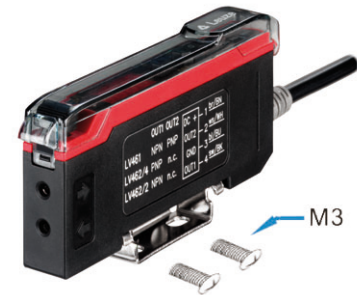
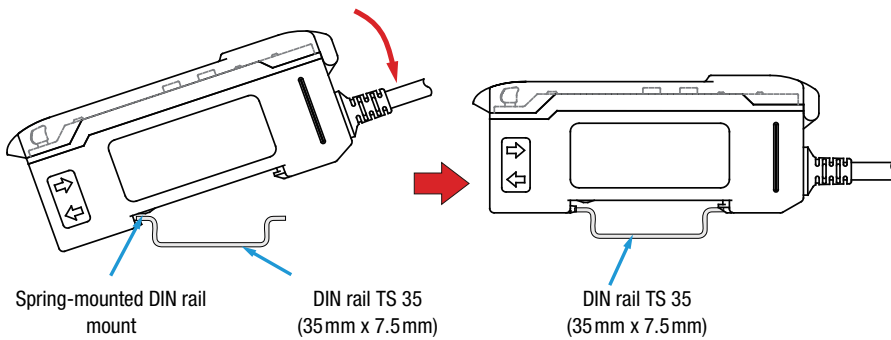

Alternatively, the amplifier can also be mounted without a DIN rail using the mounting accessory and M3 screws.

The amplifier is mounted as shown on a TS 35 DIN rail while disconnected from voltage.

### Installing the fiber optics

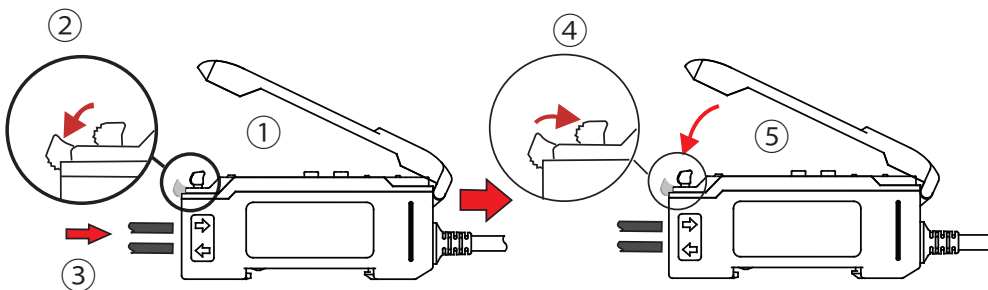





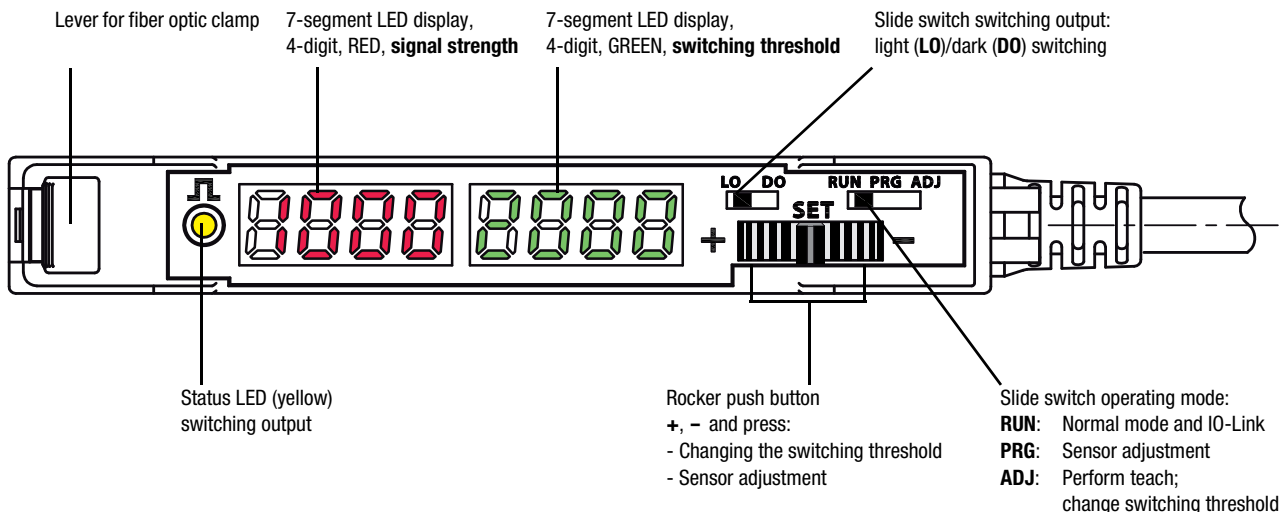

- ① Open the transparent protective cover.
- ② Push down the lever of the fiber optic clamp to open.
- ③ Lead the **KF/KFX** type fiber optics in completely as far as they will go (ca. 12mm deep) into the fiber optic intake. **When doing so, observe the transmitter/receiver assignment** on the amplifier (transmitter at bottom / receiver on top).
- ④ Pull up the lever of the fiber optic clamp to close.  
Check if the clamp is secure by pulling lightly on the fiber optics.
- ⑤ Close the transparent protective cover.

### Controls and indicators



LV463 IO-Link

Amplifier for fiber optics

	Selector switch <b>Operating mode</b>	<b>RUN:</b> Normal mode - no settings possible at the device - configuration of the IO-Link only possible in this setting <b>ADJ:</b> press rocker push button: the set teach is executed. Rock to left - right: change the switching threshold, left = + and right = -. <b>PRG:</b> menu-driven device setting via display and rocker push button
	Selector switch <b>Switching output</b>	<b>LO:</b> Switching output <b>light switching:</b> If throughbeam fiber optics are installed, the switching output is active when the light path is free; if a scanning system is installed, the switching output is active when an object is detected. The status LED illuminates when the switching output is active. <b>DO:</b> Switching output <b>dark switching:</b> The switching behavior is the inversion of the <b>light switching</b> setting.
	Rocker push button - <b>Set switching threshold</b> - <b>Navigation in menu</b>	The <b>rocker push</b> button can be rocked <b>to the right</b> and <b>to the left</b> and <b>pressed</b> in the middle position. Rock +, -: in the <b>ADJ</b> operating mode, the switching threshold can be increased (+) or decreased (-) by rocking. In the <b>PRG</b> operating mode, rock to navigate in the menu. Button: press the rocker push button in the middle position to accept a setting made in the <b>PRG</b> operating mode.
	Indicator <b>Signal strength</b>	In the <b>RUN</b> and <b>ADJ</b> operating modes, the display shows the current signal value. In the <b>PRG</b> operating mode, information on menu navigation appears on the display.
	Indicator <b>Switching threshold</b>	In the <b>RUN</b> and <b>ADJ</b> operating modes, the display shows the currently set switching threshold. In the <b>PRG</b> operating mode, information on menu navigation appears on the display.
	Status LED (yellow) <b>Switching output state</b>	<b>LED ON</b> Switching output active. <b>LED OFF</b> Switching output inactive.

**RUN operating mode - normal operation**

The RUN operating mode is the standard operating mode in which the sensor detects objects; it signals this according to the set functions. If the selector switch for the operating mode is in the **RUN** position, changes can only be made via IO-Link. This setting is thus suitable for protection against unintended operation and changes to device settings.



**PRG operating mode - sensor adjustment**

The LV463 can be adjusted to meet customer requirements with a simple menu-driven system. To do this, set the **selector switch** for the **operating mode** to position **PRG**.



The menu consists of 11 successive subfunctions. Rock to right or left to freely navigate through the subfunctions.

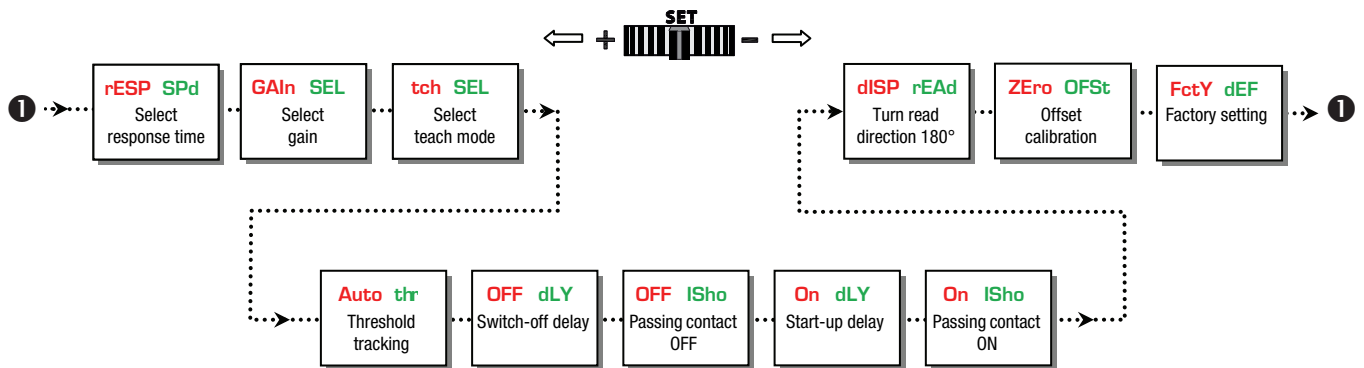

**Selecting a subfunction and changing the setting**

1. Rock to left or right to select the desired subfunction.
2. Press rocker push button in middle position. The currently set value is displayed statically.
3. Rock to right or left to display the selectable adjustment values - these flash slowly.
4. Accept the new value by pressing the rocker push button in the middle position.  
Fast flashing indicates that the new value is accepted.
5. Automatic return to the heading for the subfunction.
6. Press again to statically display the previously selected value.

**Description of the subfunctions**

Subfunction	Possible settings / value range	Factory setting (default)	Explanation
<b>rESP SPd</b> Select response time	$t_{RESP} =$ <b>200</b> (signal range HS) <b>500</b> (signal range STD) <b>2000</b> (signal range LR) <b>5000</b> $\mu$ s (signal range XLR)	<b>500</b> $\mu$ s	The response time is the max. time required by the switching output to switch to the active state following a signal change at the input. From this, the switching frequency can be calculated as follows: $f = \frac{1}{2 \cdot t_{RESP}} \text{ [Hz]}$ <b>Notice: A change to the response time is equivalent to a change to the signal range.</b>
<b>GAIIn SEL</b> Select gain	Gain stage <b>Gn 1 ... Gn 8; Auto GAIIn</b>	<b>Auto GAIIn</b>	The gain stage can be set either by manually presetting a value between <b>Gn 1 ... Gn 8</b> or automatically by selecting <b>Auto GAIIn</b> . The left, red display shows the current signal value. The gain stage should be selected so that the signal value is approximately in the middle of the display area. If <b>Auto GAIIn</b> is selected, the device automatically determines the optimum gain setting <b>during teaching</b> .
<b>tch SEL</b> Select teach mode	Teach modes <b>1 Pt tch</b> (static), <b>2 Pt tch</b> (static), <b>dYn tch</b> (dynamic)	<b>1 Pt tch</b>	Presetting a suitable teach process. To trigger the teach event, see <b>Teaching operating mode</b> . <b>1-point teach, static:</b> during teaching, the current signal value is accepted as the new switching threshold. Actuate the rocker push button to make fine adjustments to the threshold. <b>2-point teach, static:</b> the switching threshold is calculated at approximately midway between two signal values, e.g., teach to two different objects or teach to the same object at two different distances from the probe. Example: signal value 1 = 100 digits, signal value 2 = 400 digits → Switching threshold = 280 digits. Actuate the rocker push button to + or - to make fine adjustments to the threshold. <b>Dynamic teach:</b> suitable for processes that cannot be stopped for teaching. When the teach event is started, the sensor begins to scan the signal values. On the left, red display, the signal values are constantly displayed. At the end of the teach event, the switching threshold is calculated at approximately midway between the smallest and largest signal value.
<b>Auto thr</b> Threshold tracking	Tracking the switching threshold <b>oFF, On</b>	<b>oFF</b>	The function is only available during dynamic teaching. If the function is switched on, the switching threshold is automatically and continuously optimized by the sensor in such a way that maximum functional reliability is ensured. This can be used to compensate for, e.g., soiling or process changes. <b>Warning message:</b> <b>thr ALrt:</b> The limit of threshold tracking is reached - the sensor continues to operate. Cleaning and, if necessary, alignment of the fiber optics recommended <b>Error message:</b> <b>thr Err:</b> The limit of threshold tracking is exceeded - <b>the sensor stops operating</b> . Cleaning and, if necessary, alignment of the fiber optics urgently necessary
<b>OFF dLY</b> Switch-off delay	<b>0</b> (off), <b>1 ... 9999 ms</b> (milliseconds)	<b>0</b>	<b>Switch-off delay (OFF Delay):</b> Individually adjustable from 1 ... 9999 ms. Combination options → <b>Combining timing functions</b>
<b>OFF ISho</b> Passing contact OFF	<b>0</b> (off), <b>1 ... 9999 ms</b> (milliseconds)	<b>0</b>	<b>Passing contact on fall-back (OFF 1-Shot):</b> Individually adjustable from 1 ... 9999 ms. Combination options → <b>Combining timing functions</b>
<b>On dLY</b> Switch-on delay	<b>0</b> (off), <b>1 ... 9999 ms</b> (milliseconds)	<b>0</b>	<b>Switch-on delay (ON Delay):</b> Individually adjustable from 1 ... 9999 ms. Combination options → <b>Combining timing functions</b>
<b>On ISho</b> Passing contact ON	<b>0</b> (off), <b>1 ... 9999 ms</b> (milliseconds)	<b>0</b>	<b>Passing contact on actuation (ON 1-Shot):</b> Individually adjustable from 1 ... 9999 ms. Combination options → <b>Combining timing functions</b>

**LV463 IO-Link**
**Amplifier for fiber optics**

Subfunction	Possible settings / value range	Factory setting (default)	Explanation
<b>dISP rEAd</b> Turn read direction 180°	<b>dISP rEAd, pV3r dSIP</b>	<b>dISP rEAd</b> (same read direction as other texts)	Changes the <b>read direction</b> of the two 7-segment displays by 180°.
<b>ZErO OFSt</b> Offset calibration	<b>no, YES</b>	<b>no</b>	<p>This subfunction is used for <b>suppressing an offset signal</b> that can result, e.g., from crosstalk between transmitter and receiver at the fiber optic head. To activate this function, select <b>YES</b> and confirm the selection by pressing the rocker push button. The current signal value is now set to <b>0</b>. To perform another offset calibration, the previous calibration must first be reset. To do this, select <b>no</b> and confirm by pressing the rocker push button. Now again perform the offset calibration as previously described.</p> <p><b>Notice:</b>      <b>Resolution is lost when using offset suppression!</b>                      Example: display area = 4000 digits, offset value = 550 digits                      → Remaining resolution = 3450 digits</p>
<b>FctY dEF</b> Factory setting	<b>no, YES</b>	<b>no</b>	<p><b>Attention!</b>  <b>Resets all sensor settings to factory settings.</b>                      If desired, select <b>YES</b> and execute by pressing the rocker push button.</p>

**Tip!**

The maximum operating range can be achieved as follows:

- Set **rESP SPd** to **5000µs** (signal range **XLR**).
- Set **GAIIn SEL** to **Gn 8** (gain stage 8).
- The switching threshold can be set to minimum 32 digits, the amplifier detects objects up to display value **0**.

Time functions

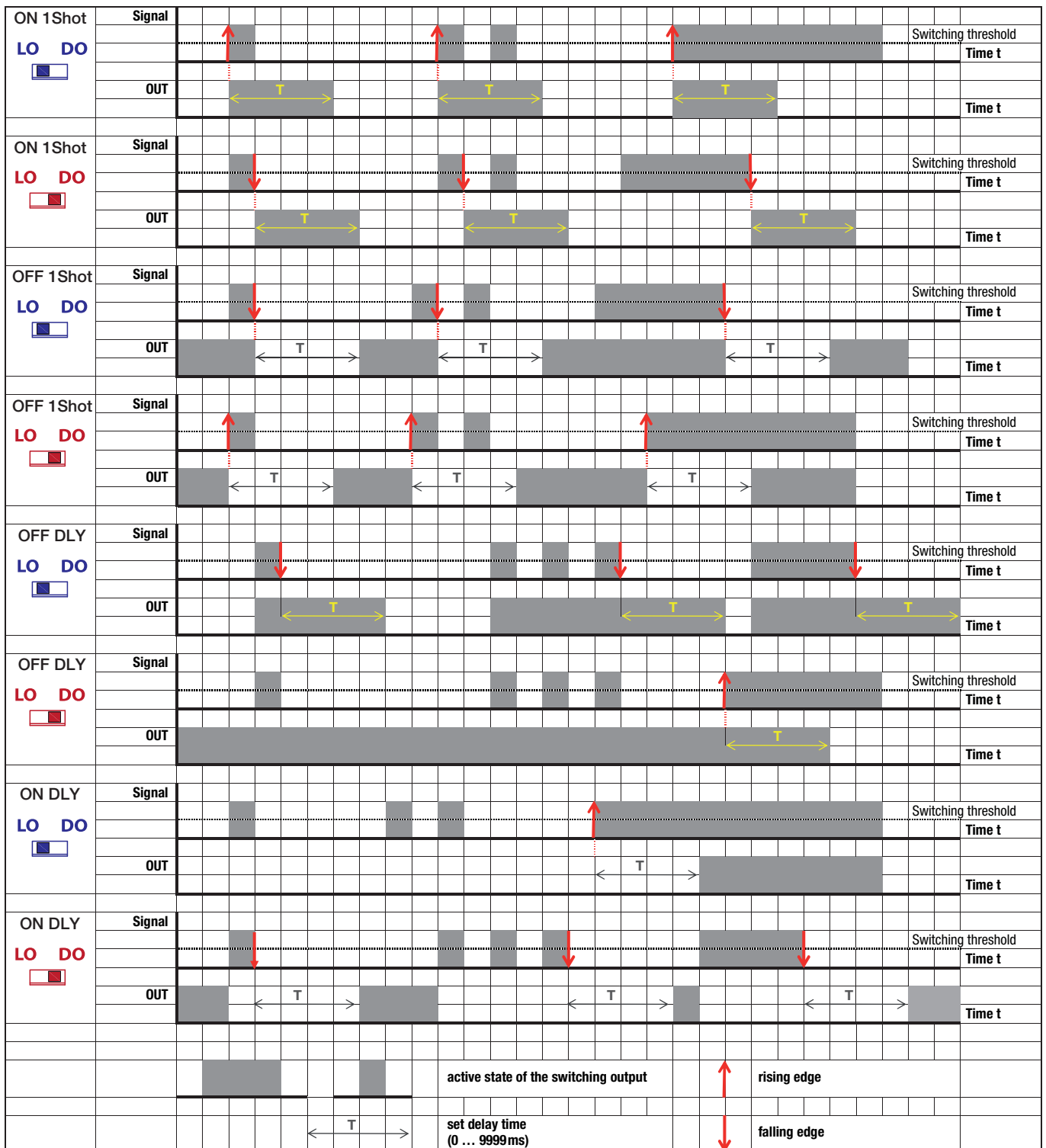

### Combining timing functions

Timing functions can only be combined to a limited extent. Impermissible combinations are suppressed from the subfunctions menu. Here is an overview of the permissible combinations (●):

	OFF dLY Switch-off delay	OFF ISho Passing contact OFF	On dLY Switch-on delay	On ISho Passing contact ON
OFF dLY Switch-off delay		●	●	
OFF ISho Passing contact OFF	●			
On dLY Switch-on delay	●			●
On ISho Passing contact ON			●	

### Teaching operating mode

Set the selector switch for the operating mode to the **ADJ** position.



Depending on the setting of the **Select teach mode** subfunction (**tch SEL**), one of the following teach modes appears:

- **Static 1-point teach**
- **Static 2-point teach**
- **Dynamic teach**

### Teach process

Step	Static 1-point teach	Static 2-point teach	Dynamic teach
①	Place object in light beam. The red display shows the signal value, the green display the current switching threshold.	Place object in light beam. The red display shows the signal value, the green display the current switching threshold.	Press the rocker push button. The green display shows <b>dYn</b> , the red display the current signal value. The amplifier now scans signal values for approx. 1 minute.
②	Press the rocker push button; the teach value is accepted.	Press the rocker push button, <b>first</b> teach value is accepted.	Move several objects through the light beam; to end the event, press the rocker push button again. After the scanning time elapses, the teach event ends automatically.
③	Following a successful teach, <b>PASS</b> appears on the green display and the signal value is displayed as the new switching threshold. In the event of a faulty teach, <b>FAIL</b> appears on the red display. In this case, the signal value may be too small and cannot be accepted as a teach value (→ <b>Table with minimum teach values as a function of the setting</b> ). Check object and/or placement and repeat event.	<b>2nd</b> appears on the green display; the red display shows the current signal value. Place object 2 or object at distance 2 and press the rocker push button <b>within one minute</b> . The <b>second</b> teach value is accepted. If the rocker push button is not pressed within one minute, the teach event is interrupted and the previous switching threshold is retained. Following a successful teach, <b>PASS</b> appears on the green display. The new switching threshold now lies approximately midway between the two taught signal values. In the event of a faulty teach, <b>FAIL</b> appears on the red display. In this case, the minimum distance between the two teach points may be too small (→ <b>Table with minimum teach values as a function of the setting</b> ). Try to set a larger distance between the two signal values and repeat the event.	Following a successful teach, <b>PASS</b> appears on the green display. The new switching threshold now lies between the maximum and the minimum of the scanned signal values. In the event of a faulty teach, <b>FAIL</b> appears on the red display. In this case, the minimum distance between the scanned signal values may be too small (→ <b>Table with minimum teach values as a function of the setting</b> ). Try to set a larger distance between the signal values and repeat the event.
④	The switching threshold can be freely increased or decreased at a later time by rocking the rocker push button to the left (+) and right (-). The change is accepted if both displays flash briefly several times.	The switching threshold can be freely increased or decreased at a later time by rocking the rocker push button to the left (+) and right (-). The change is accepted if both displays flash briefly several times.	The switching threshold can be freely increased or decreased at a later time by rocking the rocker push button to the left (+) and right (-). The change is accepted if both displays flash briefly several times.

**Tip!**

For reliable function, the difference between the signal value while an object is present and the signal value with no object should be at least 10 ... 20%. In general: the larger the difference, the more reliable the detection.

**Table with minimum teach values as a function of the setting**

	Static 1-point teach:				Static 2-point teach Dynamic teach:			
	MINIMUM VALUES for setting the switching threshold				DIFFERENCE between teach values 1 and 2			
Signal range	HS	STD	LR	XLR	HS	STD	LR	XLR
Display area (digits)	0 ... 4000	0 ... 4000	0 ... 9999	0 ... 9999	0 ... 4000	0 ... 4000	0 ... 9999	0 ... 9999
Response time [µs]	200	500	2000	5000	200	500	2000	5000
Gain <b>Gn 1</b>	27	27	17	11	36	36	22	14
Gain <b>Gn 2</b>	27	27	17	11	36	36	22	14
Gain <b>Gn 3</b>	27	27	17	11	36	36	22	14
Gain <b>Gn 4</b>	41	41	27	17	54	54	36	22
Gain <b>Gn 5</b>	41	41	27	17	54	54	36	22
Gain <b>Gn 6</b>	41	41	27	17	54	54	36	22
Gain <b>Gn 7</b>	53	53	32	21	70	70	42	28
Gain <b>Gn 8</b>	78	78	48	32	104	104	64	42

■ = values for the following examples.

**Example 1:**

- 1-point teach, static
- Standard signal range (**STD**) = response time **500µs**
- Gain **Gn 3**

The **signal value during teaching** must be  $\geq 27$  digits.

**Example 2:**

- 2-point teach, static
- Standard signal range (**STD**) = response time **500µs**
- Gain **Gn 5**
- **Teach value 1 = 150 digits**

The **signal value for teach point 2** must be  $\geq 204$  digits or  $\leq 96$  digits.